

MODEL HV-35

Hand-Held Probe

- >> Locates pinholes and flaws in dielectric materials and coatings
- >> Variety of probe tips available
- >> Simple to operate
- >> Non-destructive, safe

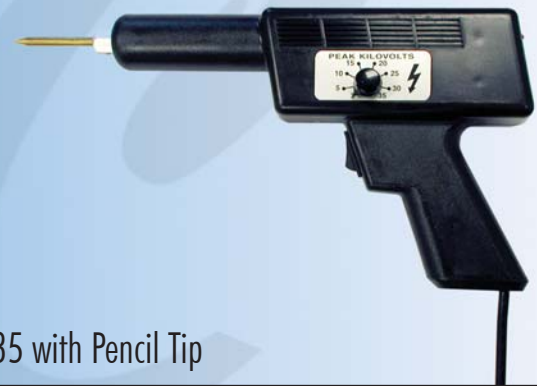

HV-35 with Pencil Tip

The Model HV-35 Hand-Held Probe is a versatile tool used to detect pinholes and defects in a wide range of different product types. Originally developed to pinpoint insulation flaws in wire and cable, the HV-35 is now widely employed to find pinholes in the plastic coatings of surgical instruments, holidays in tank linings and defects in dielectric coatings on metal pipes or sheets.

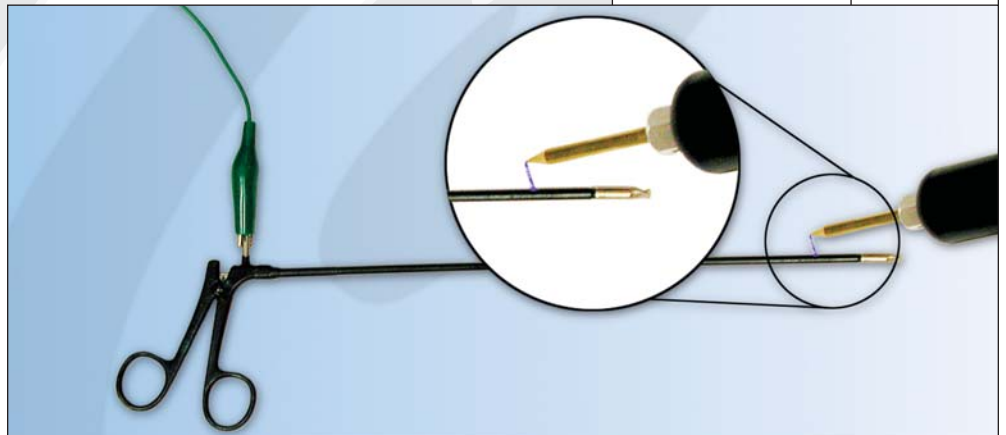

Lightweight and portable, the HV-35 applies an adjustable, non-destructive voltage to the test surface with the touch of the trigger. When a defect in the dielectric material is encountered, an audible buzzer sounds and an LED lights to alert the operator. An arc is generated to the flaw allowing the operator to pinpoint the defect visually.

Several probe tips styles -- pencil point, brush or hook-- are available to suit the application. The HV-35 is line-operated and current limited for the safety of operating personnel.



Clinton
INSTRUMENT COMPANY

HV-35

SPECIFICATIONS

Voltage Test Range2-35KV peak adjustable.

Voltage IndicationFixed scale.

WaveformNegative impulse.

Frequency60 i.p.s.

Energy40 milliJoules.

Fault IndicationSonic alarm and LED indicator.

Output CurrentLess than 200 ma. @ 35kV.

Dimensions10.9"L x 6.8"H x 2.8"W (277 mm L x 173 mm H x 701 mm W), with a 6' long power cord.

Weight2 lbs. (0.9 kg.).

Probe Tip StylesPencil
Hook (2" max. product diameter)
Brush, 2" wide.

Power Requirements120VAC 2 amps 50/60 Hz . If 240VAC operation is desired, a stepdown transformer may be purchased.

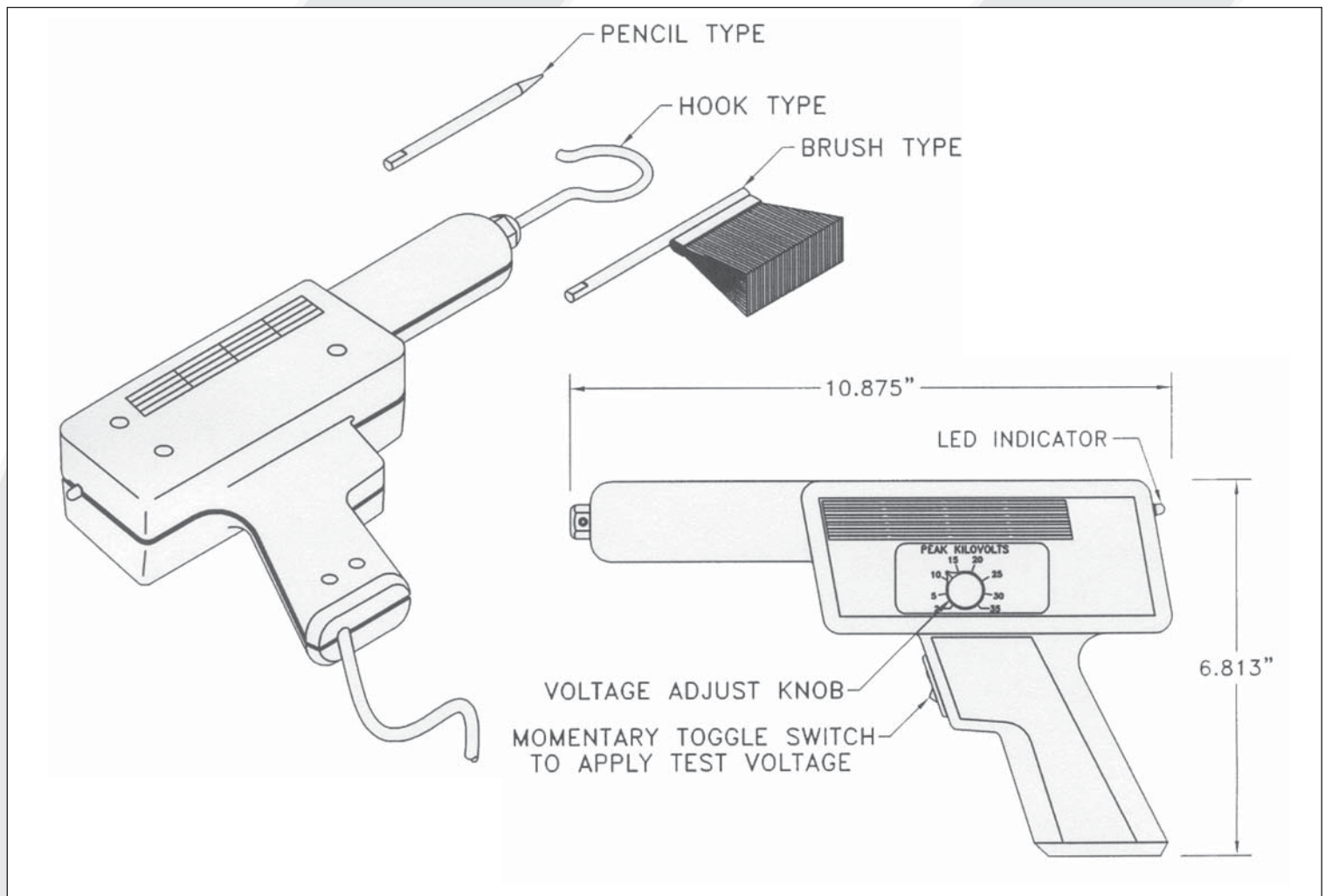

Clinton
INSTRUMENT COMPANY

295 East Main St. • Clinton, CT 06413 USA • Tel: 860.669.7548 • Fax: 860.669.3825 • www.clintoninstrument.com

Specifications subject to change without notice. 06/04 EN